

SYNCHRONOUS PRESETTABLE 4-BIT COUNTER

- HIGH SPEED:
 $f_{MAX} = 180 \text{ MHz (TYP.) at } V_{CC} = 3.3 \text{ V}$
- COMPATIBLE WITH TTL OUTPUTS
- LOW POWER DISSIPATION:
 $I_{CC} = 4 \mu\text{A (MAX.) at } T_A = 25^\circ\text{C}$
- LOW NOISE:
 $V_{OLP} = 0.3\text{V (TYP.) at } V_{CC} = 3.3\text{V}$
- 75Ω TRANSMISSION LINE DRIVING CAPABILITY
- SYMMETRICAL OUTPUT IMPEDANCE:
 $|I_{OH}| = I_{OL} = 12\text{mA (MIN) at } V_{CC} = 3.0 \text{ V}$
- PCI BUS LEVELS GUARANTEED AT 24 mA
- BALANCED PROPAGATION DELAYS:
 $t_{PLH} \cong t_{PHL}$
- OPERATING VOLTAGE RANGE:
 $V_{CC(OPR)} = 2\text{V to } 3.6\text{V (1.2V Data Retention)}$
- PIN AND FUNCTION COMPATIBLE WITH 74 SERIES 163
- IMPROVED LATCH-UP IMMUNITY

DESCRIPTION

The 74LVQ163 is a low voltage CMOS SYNCHRONOUS PRESETTABLE COUNTER fabricated with sub-micron silicon gate and double-layer metal wiring C²MOS technology. It is ideal for low power and low noise 3.3V applications. It is a 4 bit binary counter with Synchronous Clear.

The circuit have four fundamental modes of operation, in order of preference: synchronous reset, parallel load, count-up and hold. Four

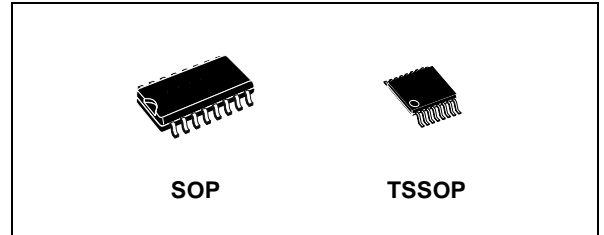

Table 1: Order Codes

PACKAGE	T & R
SOP	74LVQ163MTR
TSSOP	74LVQ163TTR

control inputs, Master Reset (CLEAR), Parallel Enable Input (LOAD), Count Enable Input (PE) and Count Enable Carry Input (TE), determine the mode of operation as shown in the Truth Table. A LOW signal on CLEAR overrides counting and parallel loading and allows all outputs to go LOW on the next rising edge of CLOCK. A LOW signal on LOAD overrides counting and allows information on Parallel Data Qn inputs to be loaded into the flip-flops on the next rising edge of CLOCK. With LOAD and CLEAR, PE and TE permit counting when both are high. Conversely, a LOW signal on either PE and TE inhibits counting. All inputs and outputs are equipped with protection circuits against static discharge, giving them 2KV ESD immunity and transient excess voltage.

Figure 1: Pin Connection And IEC Logic Symbols

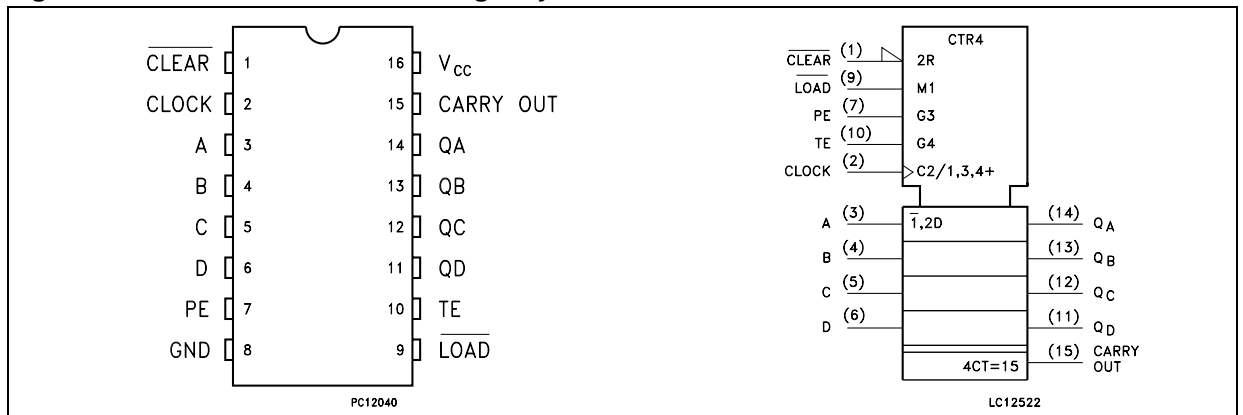

Figure 2: Input And Output Equivalent Circuit

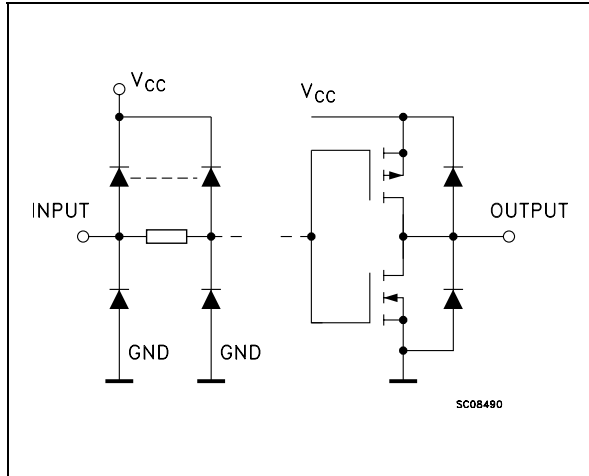

Table 2: Pin Description

PIN N°	SYMBOL	NAME AND FUNCTION
1	CLEAR	Synchronous Master Reset
2	CLOCK	Clock Input (Positive Edge Trigger)
3, 4, 5, 6	A, B, C, D	Data Inputs
7	PE	Count Enable Input
10	TE	Count Enable Carry Input
9	LOAD	Parallel Enable Input
14, 13, 12, 11	QA to QD	Flip-Flop Outputs
15	CARRY OUT	Terminal Count Output
8	GND	Ground (0V)
16	V _{CC}	Positive Supply Voltage

Table 3: Truth Table

INPUTS					OUTPUTS				FUNCTION
CLEAR	LOAD	PE	TE	CK					
L	X	X	X		L	L	L	L	RESET TO "0"
H	L	X	X		A	B	C	D	PRESET DATA
H	H	X	L		NO CHANGE				NO COUNT
H	H	L	X		NO CHANGE				NO COUNT
H	H	H	H		COUNT UP				COUNT
H	X	X	X		NO CHANGE				NO COUNT

X : Don't Care; A, B, C, D; Logic level of data input; CARRY OUT : TE x QA x QB x QC x QD

Figure 3: Logic Diagram

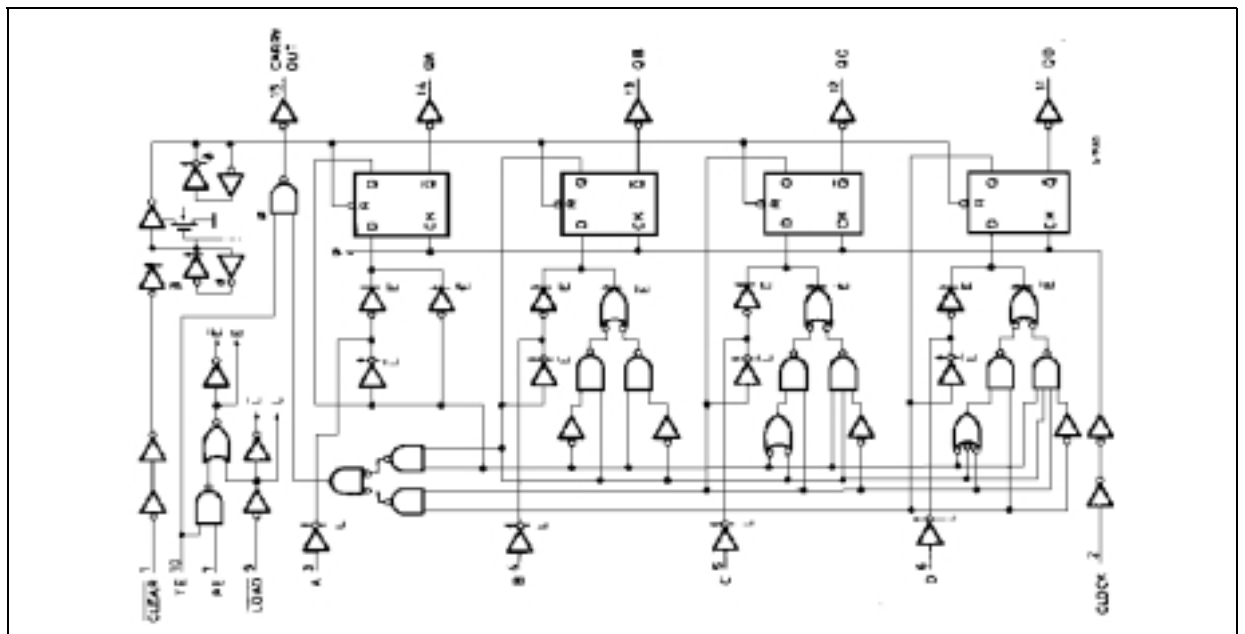

Figure 4: Timing Chart

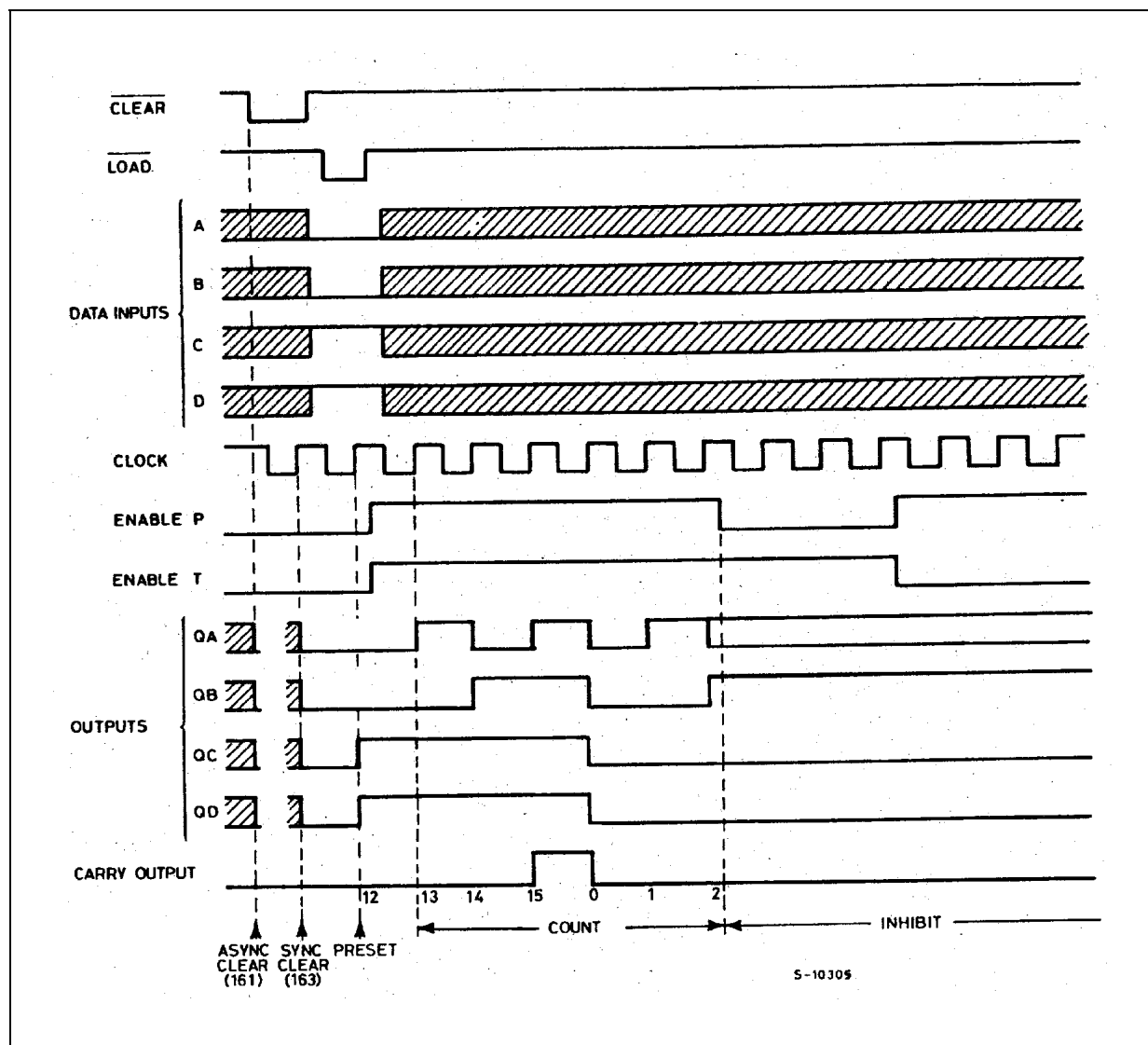

Table 4: Absolute Maximum Ratings

Symbol	Parameter	Value	Unit
V_{CC}	Supply Voltage	-0.5 to +7	V
V_I	DC Input Voltage	-0.5 to $V_{CC} + 0.5$	V
V_O	DC Output Voltage	-0.5 to $V_{CC} + 0.5$	V
I_{IK}	DC Input Diode Current	± 20	mA
I_{OK}	DC Output Diode Current	± 20	mA
I_O	DC Output Current	± 50	mA
I_{CC} or I_{GND}	DC V_{CC} or Ground Current	± 300	mA
T_{stg}	Storage Temperature	-65 to +150	$^{\circ}C$
T_L	Lead Temperature (10 sec)	300	$^{\circ}C$

Absolute Maximum Ratings are those values beyond which damage to the device may occur. Functional operation under these conditions is not implied.

Table 5: Recommended Operating Conditions

Symbol	Parameter	Value	Unit
V_{CC}	Supply Voltage (note 1)	2 to 3.6	V
V_I	Input Voltage	0 to V_{CC}	V
V_O	Output Voltage	0 to V_{CC}	V
T_{op}	Operating Temperature	-55 to 125	°C
dt/dv	Input Rise and Fall Time $V_{CC} = 3.0V$ (note 2)	0 to 10	ns/V

1) Truth Table guaranteed: 1.2V to 3.6V

2) V_{IN} from 0.8V to 2V

Table 6: DC Specifications

Symbol	Parameter	Test Condition		Value						Unit	
				$T_A = 25^\circ\text{C}$			-40 to 85°C		-55 to 125°C		
				Min.	Typ.	Max.	Min.	Max.	Min.		Max.
V_{IH}	High Level Input Voltage	3.0 to 3.6		2.0			2.0		2.0		V
V_{IL}	Low Level Input Voltage				0.8		0.8		0.8		V
V_{OH}	High Level Output Voltage	3.0	$I_O = -50 \mu\text{A}$	2.9	2.99		2.9		2.9		V
			$I_O = -12 \text{ mA}$	2.58			2.48		2.48		
			$I_O = -24 \text{ mA}$				2.2		2.2		
V_{OL}	Low Level Output Voltage	3.0	$I_O = 50 \mu\text{A}$		0.002	0.1		0.1		0.1	V
			$I_O = 12 \text{ mA}$		0	0.36		0.44		0.44	
			$I_O = 24 \text{ mA}$					0.55		0.55	
I_I	Input Leakage Current	3.6	$V_I = V_{CC}$ or GND			± 0.1		± 1		± 1	μA
I_{CC}	Quiescent Supply Current	3.6	$V_I = V_{CC}$ or GND			4		40		40	μA
I_{OLD}	Dynamic Output Current (note 1, 2)	3.6	$V_{OLD} = 0.8 \text{ V max}$				36		25		mA
I_{OHD}			$V_{OHD} = 2 \text{ V min}$				-25		-25		mA

1) Maximum test duration 2ms, one output loaded at time

2) Incident wave switching is guaranteed on transmission lines with impedances as low as 75 Ω

Table 7: Dynamic Switching Characteristics

Symbol	Parameter	Test Condition		Value						Unit	
				$T_A = 25^\circ\text{C}$			-40 to 85°C		-55 to 125°C		
				Min.	Typ.	Max.	Min.	Max.	Min.		Max.
V_{OLP}	Dynamic Low Voltage Quiet Output (note 1, 2)	3.3	$C_L = 50 \text{ pF}$		0.3	0.8					V
V_{OLV}				-0.8	-0.3						
V_{IHD}	Dynamic High Voltage Input (note 1, 3)	3.3		2							V
V_{ILD}	Dynamic Low Voltage Input (note 1, 3)	3.3				0.8					V

1) Worst case package.

2) Max number of outputs defined as (n). Data inputs are driven 0V to 3.3V, (n-1) outputs switching and one output at GND.

3) Max number of data inputs (n) switching. (n-1) switching 0V to 3.3V. Inputs under test switching: 3.3V to threshold (V_{ILD}), 0V to threshold (V_{IHD}), $f = 1\text{MHz}$.

Table 8: AC Electrical Characteristics ($C_L = 50 \text{ pF}$, $R_L = 500 \Omega$, Input $t_r = t_f = 3\text{ns}$)

Symbol	Parameter	Test Condition		Value						Unit	
		V_{CC} (V)		$T_A = 25^\circ\text{C}$			$-40 \text{ to } 85^\circ\text{C}$		$-55 \text{ to } 125^\circ\text{C}$		
				Min.	Typ.	Max.	Min.	Max.	Min.		Max.
t_{PLH} t_{PHL}	Propagation Delay Time CK to Q	2.7			7.5	12.0		15.0		17.0	ns
		3.3(*)			6.3	9.5		11.0		12.5	
t_{PLH} t_{PHL}	Propagation Delay Time CK to CARRY OUT	2.7			8.8	14.0		16.0		18.5	ns
		3.3(*)			7.1	10.5		12.0		14.0	
t_{PLH} t_{PHL}	Propagation Delay Time TE to CARRY OUT	2.7			6.1	10.0		11.5		13.0	ns
		3.3(*)			5.2	8.0		9.5		10.5	
t_W	CK pulse Width, (Count) High or LOW	2.7		4.0	1.9		4.0		4.0		ns
		3.3(*)		3.0	1.9		3.0		3.0		
t_W	CK pulse Width, (Load) High or LOW	2.7		4.0	1.9		4.0		4.0		ns
		3.3(*)		3.0	1.9		3.0		3.0		
t_s	Setup Time HIGH or LOW (INPUT to CLOCK)	2.7		5.0	2.5		5.0		5.0		ns
		3.3(*)		4.0	2.1		4.0		4.0		
t_h	Hold Time HIGH or LOW (INPUT to CLOCK)	2.7		1	-1.6		1		1		ns
		3.3(*)		0.5	-1.2		0.5		0.5		
t_s	Setup Time HIGH or LOW (CLEAR to CLOCK)	2.7		3.0	1.5		3.0		3.0		ns
		3.3(*)		2.5	1.2		2.5		2.5		
t_h	Hold Time HIGH or LOW (CLEAR to CLOCK)	2.7		1	-0.6		1		1		ns
		3.3(*)		0.5	-0.5		0.5		0.5		
t_s	Setup Time HIGH or LOW (LOAD to CLOCK)	2.7		8.0	3.7		8.0		8.0		ns
		3.3(*)		6.0	3.2		6.0		6.0		
t_h	Hold Time HIGH or LOW (LOAD to CLOCK)	2.7		0	-3.0		0		0		ns
		3.3(*)		0	-2.5		0		0		
t_s	Setup Time HIGH or LOW (PE or TE to CLOCK)	2.7		7.0	3.4		7.0		7.0		ns
		3.3(*)		6.0	3.0		6.0		6.0		
t_h	Hold Time HIGH or LOW (PE or TE to CLOCK)	2.7		0	-2.6		0		0		ns
		3.3(*)		0	-2.2		0		0		
f_{MAX}	Maximum Clock Frequency	2.7		100	150		80		60		MHz
		3.3(*)		120	180		100		80		
t_{OSLH} t_{OSHL}	Output To Output Skew Time (note1, 2)	2.7			0.5	1.0		1.0		1.0	ns
		3.3(*)			0.5	1.0		1.0		1.0	

1) Skew is defined as the absolute value of the difference between the actual propagation delay for any two outputs of the same device switching in the same direction, either HIGH or LOW ($t_{OSLH} = |t_{PLHm} - t_{PLHn}|$, $t_{OSHL} = |t_{PHLm} - t_{PHLn}|$)

2) Parameter guaranteed by design

(*) Voltage range is $3.3V \pm 0.3V$

Table 9: Capacitive Characteristics

Symbol	Parameter	Test Condition		Value						Unit	
		V _{CC} (V)		T _A = 25°C			-40 to 85°C		-55 to 125°C		
				Min.	Typ.	Max.	Min.	Max.	Min.		Max.
C _{IN}	Input Capacitance	3.3			4						pF
C _{PD}	Power Dissipation Capacitance (note 1)	3.3	f _{IN} = 10MHz		33						pF

1) C_{PD} is defined as the value of the IC's internal equivalent capacitance which is calculated from the operating current consumption without load. (Refer to Test Circuit). Average operating current can be obtained by the following equation. I_{CC(opr)} = C_{PD} × V_{CC} × f_{IN} + I_{CC}/n (per circuit)

Figure 5: Test Circuit

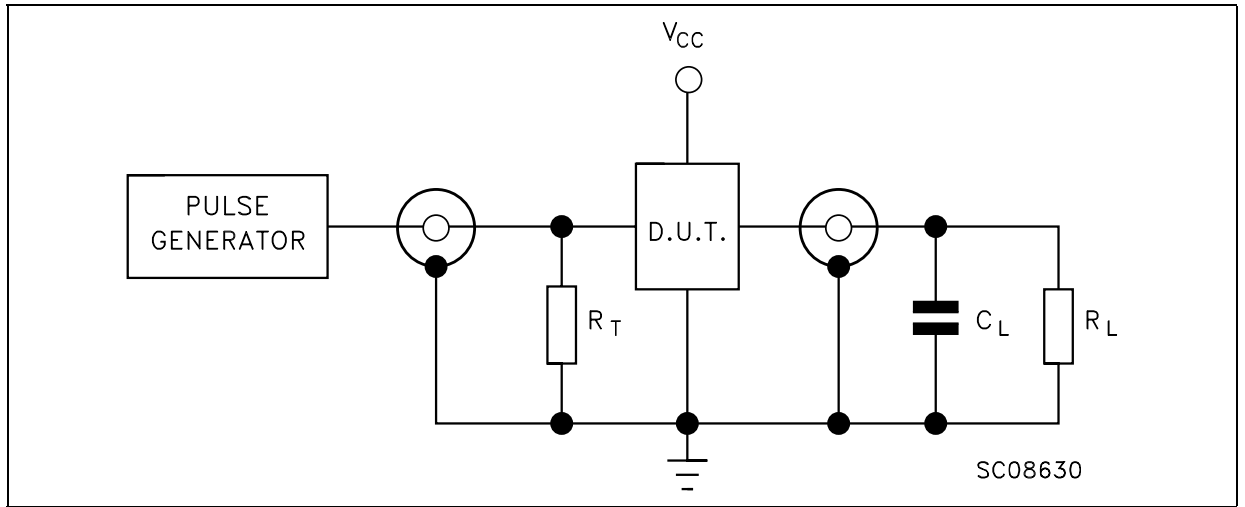

C_L = 50pF or equivalent (includes jig and probe capacitance)
 R_L = 500Ω or equivalent
 R_T = Z_{OUT} of pulse generator (typically 50Ω)

Figure 6: Waveform - Propagation Delays, Count Mode (f=1MHz; 50% duty cycle)

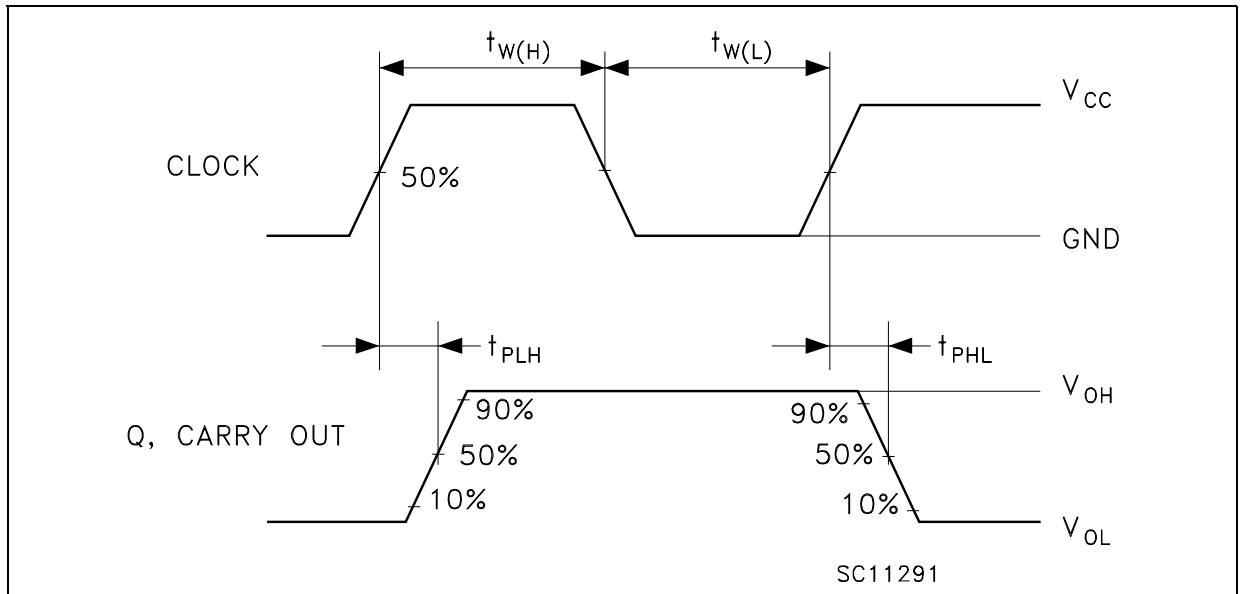

Figure 7: Waveform - Propagation Delays Clear Mode ($f=1\text{MHz}$; 50% duty cycle)

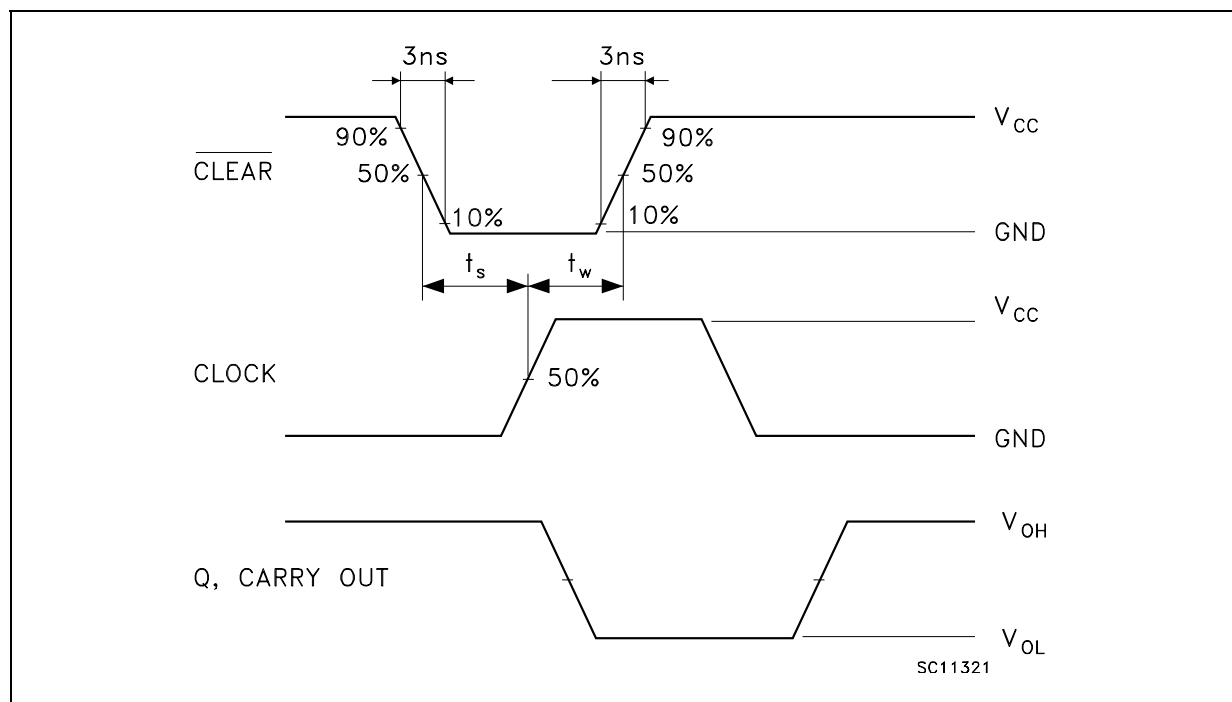

Figure 8: Waveform - Propagation Delays Preset Mode ($f=1\text{MHz}$; 50% duty cycle)

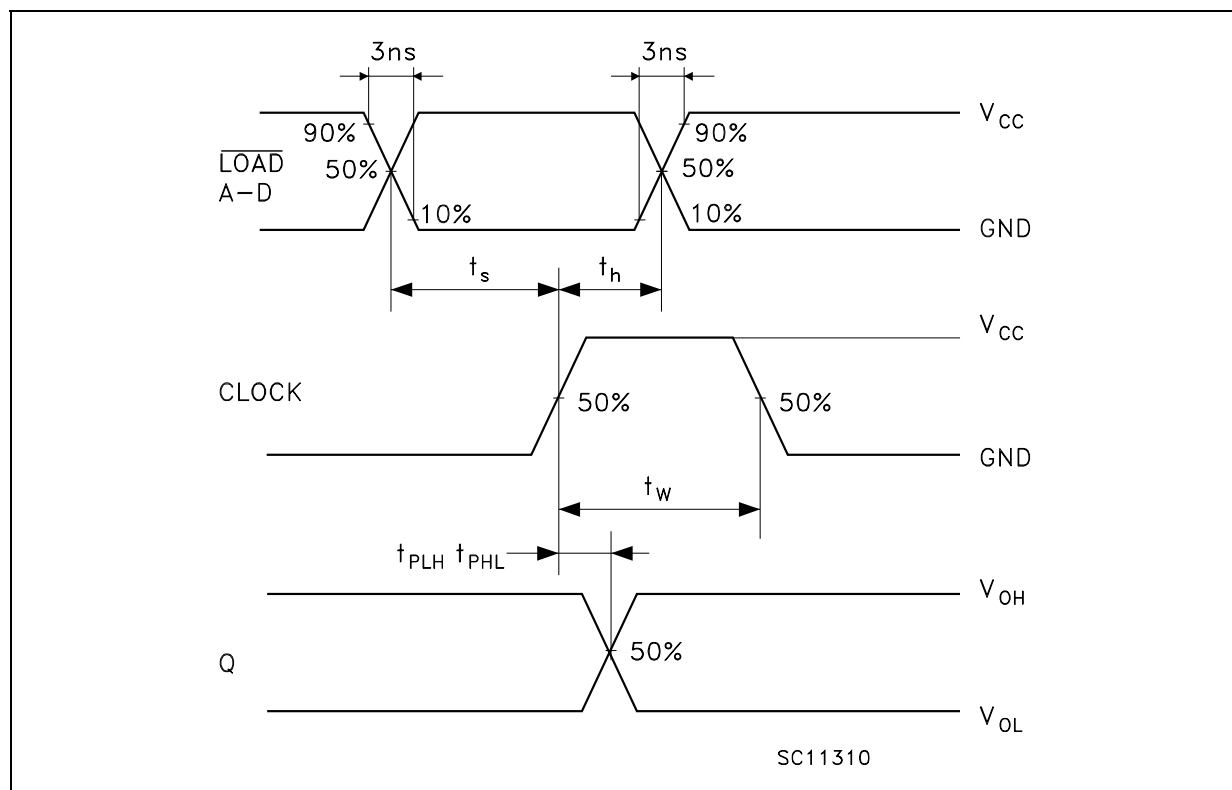
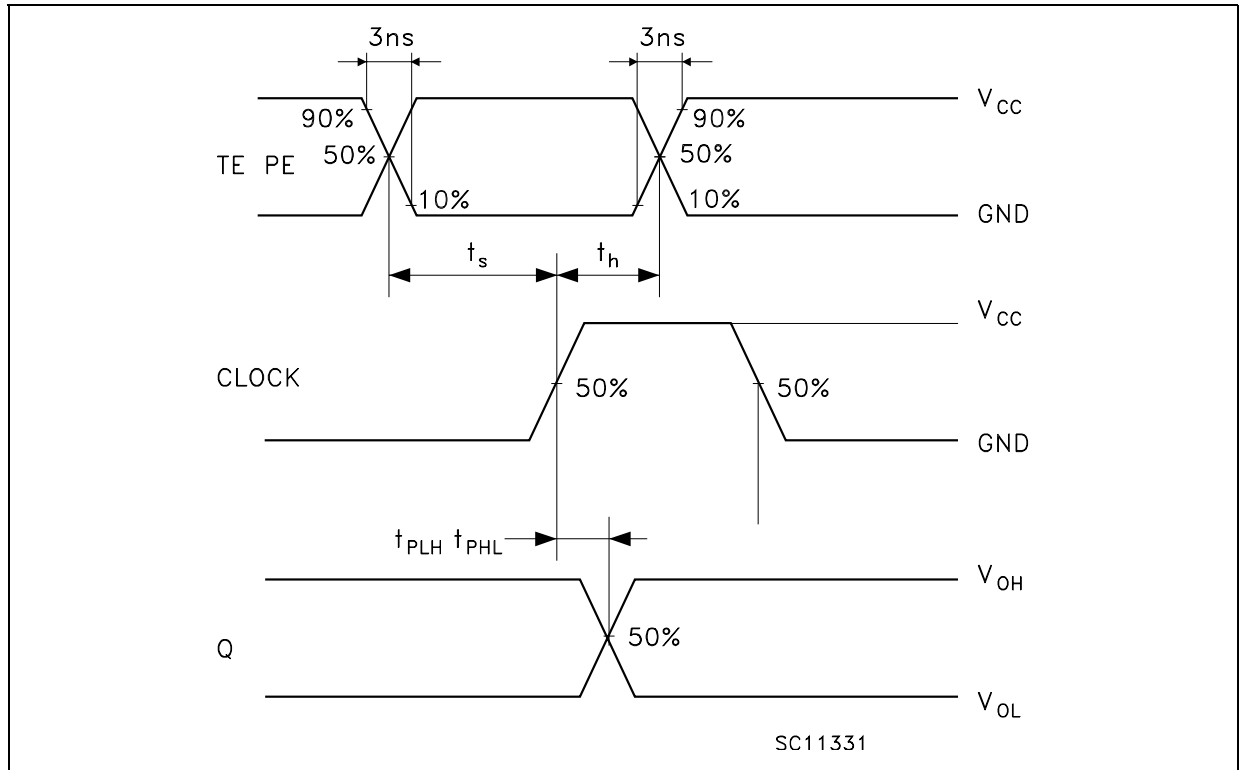
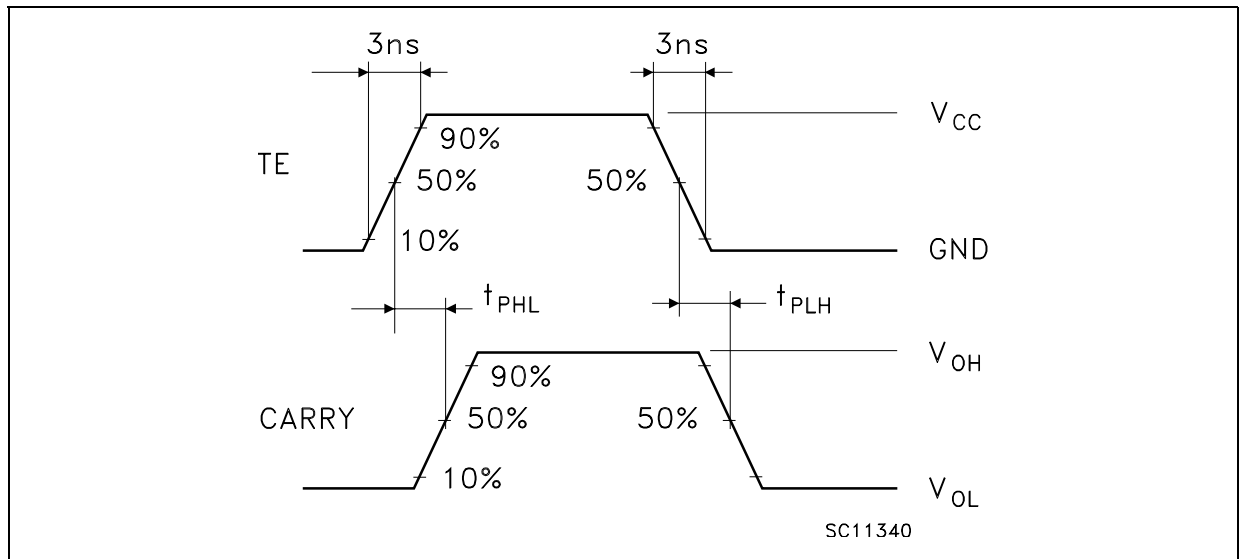
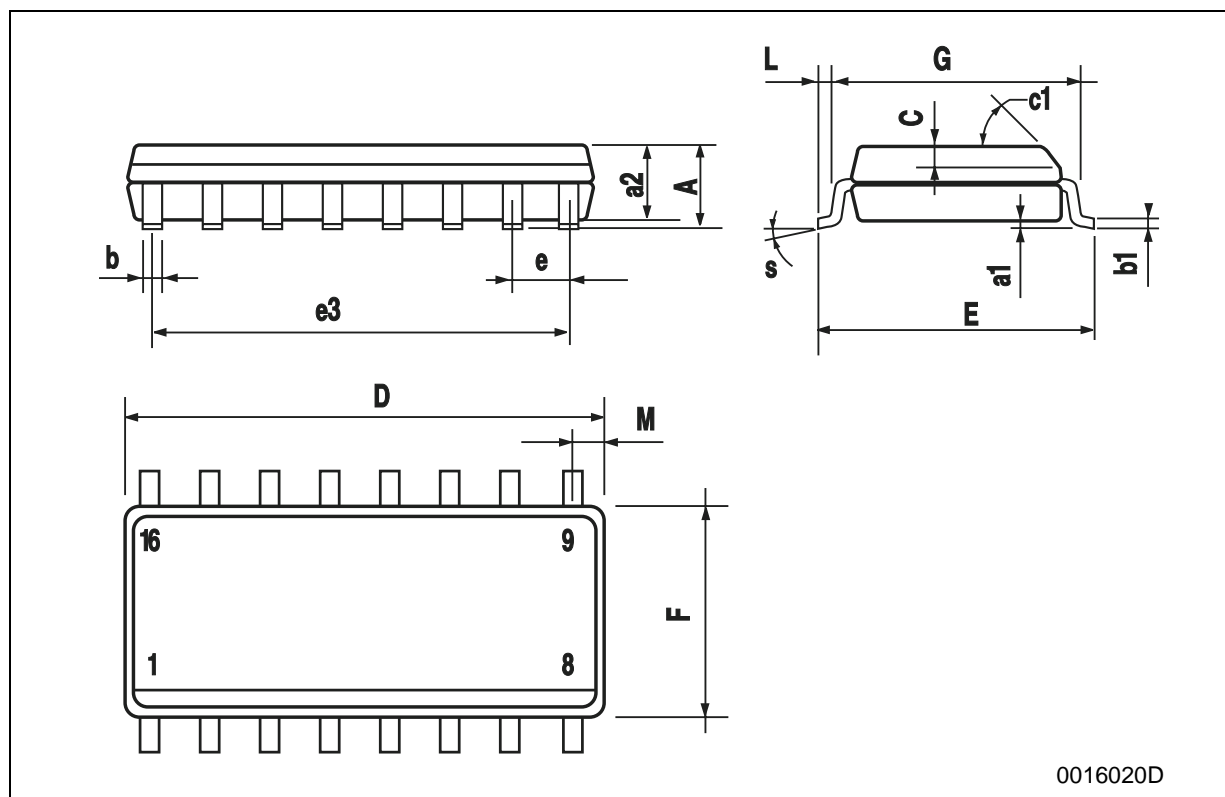

Figure 9: Waveform - Propagation Delays Countable Mode ($f=1\text{MHz}$; 50% duty cycle)Figure 10: Waveform - Propagation Delays Cascade Mode ($f=1\text{MHz}$; 50% duty cycle)

SO-16 MECHANICAL DATA

DIM.	mm.			inch		
	MIN.	TYP.	MAX.	MIN.	TYP.	MAX.
A			1.75			0.068
a1	0.1		0.25	0.004		0.010
a2			1.64			0.063
b	0.35		0.46	0.013		0.018
b1	0.19		0.25	0.007		0.010
C		0.5			0.019	
c1	45° (typ.)					
D	9.8		10	0.385		0.393
E	5.8		6.2	0.228		0.244
e		1.27			0.050	
e3		8.89			0.350	
F	3.8		4.0	0.149		0.157
G	4.6		5.3	0.181		0.208
L	0.5		1.27	0.019		0.050
M			0.62			0.024
S	8° (max.)					



TSSOP16 MECHANICAL DATA

DIM.	mm.			inch		
	MIN.	TYP	MAX.	MIN.	TYP.	MAX.
A			1.2			0.047
A1	0.05		0.15	0.002	0.004	0.006
A2	0.8	1	1.05	0.031	0.039	0.041
b	0.19		0.30	0.007		0.012
c	0.09		0.20	0.004		0.0079
D	4.9	5	5.1	0.193	0.197	0.201
E	6.2	6.4	6.6	0.244	0.252	0.260
E1	4.3	4.4	4.48	0.169	0.173	0.176
e		0.65 BSC			0.0256 BSC	
K	0°		8°	0°		8°
L	0.45	0.60	0.75	0.018	0.024	0.030

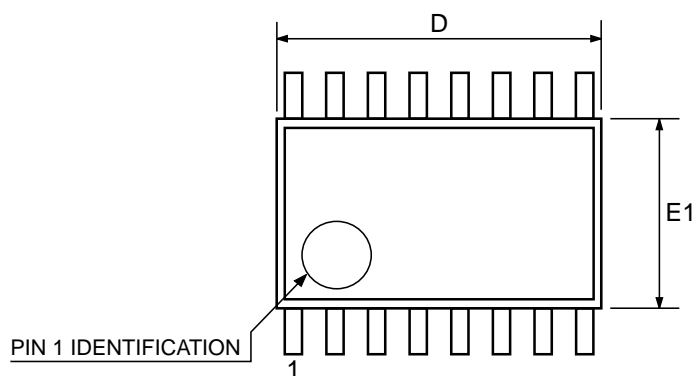
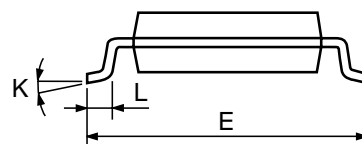
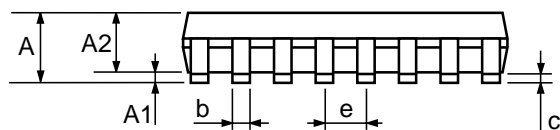

0080338D

Tape & Reel SO-16 MECHANICAL DATA

DIM.	mm.			inch		
	MIN.	TYP	MAX.	MIN.	TYP.	MAX.
A			330			12.992
C	12.8		13.2	0.504		0.519
D	20.2			0.795		
N	60			2.362		
T			22.4			0.882
Ao	6.45		6.65	0.254		0.262
Bo	10.3		10.5	0.406		0.414
Ko	2.1		2.3	0.082		0.090
Po	3.9		4.1	0.153		0.161
P	7.9		8.1	0.311		0.319



Tape & Reel TSSOP16 MECHANICAL DATA

DIM.	mm.			inch		
	MIN.	TYP	MAX.	MIN.	TYP.	MAX.
A			330			12.992
C	12.8		13.2	0.504		0.519
D	20.2			0.795		
N	60			2.362		
T			22.4			0.882
Ao	6.7		6.9	0.264		0.272
Bo	5.3		5.5	0.209		0.217
Ko	1.6		1.8	0.063		0.071
Po	3.9		4.1	0.153		0.161
P	7.9		8.1	0.311		0.319

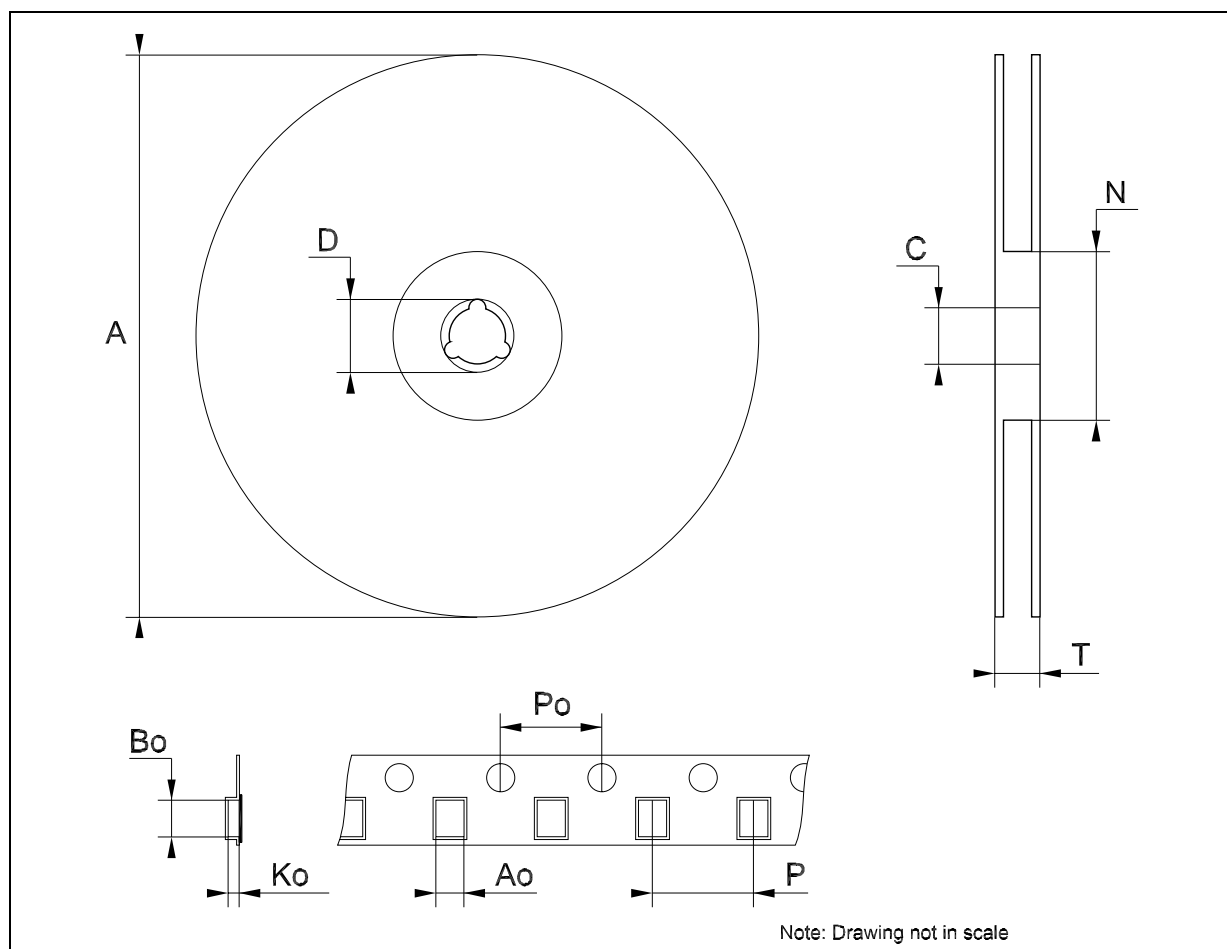

Table 10: Revision History

Date	Revision	Description of Changes
29-Jul-2004	2	Ordering Codes Revision - pag. 1.

Information furnished is believed to be accurate and reliable. However, STMicroelectronics assumes no responsibility for the consequences of use of such information nor for any infringement of patents or other rights of third parties which may result from its use. No license is granted by implication or otherwise under any patent or patent rights of STMicroelectronics. Specifications mentioned in this publication are subject to change without notice. This publication supersedes and replaces all information previously supplied. STMicroelectronics products are not authorized for use as critical components in life support devices or systems without express written approval of STMicroelectronics.

The ST logo is a registered trademark of STMicroelectronics

All other names are the property of their respective owners

© 2004 STMicroelectronics - All Rights Reserved

STMicroelectronics group of companies

Australia - Belgium - Brazil - Canada - China - Czech Republic - Finland - France - Germany - Hong Kong - India - Israel - Italy - Japan - Malaysia - Malta - Morocco - Singapore - Spain - Sweden - Switzerland - United Kingdom - United States of America

www.st.com

О компании

ООО "ТрейдЭлектроникс" - это оперативные поставки широкого спектра электронных компонентов отечественного и импортного производства напрямую от производителей и с крупнейших мировых складов. Реализуемая нашей компанией продукция насчитывает более полумиллиона наименований.

Благодаря этому наша компания предлагает к поставке практически не ограниченный ассортимент компонентов как оптовыми, мелкооптовыми партиями, так и в розницу.

Наличие собственной эффективной системы логистики обеспечивает надежную поставку продукции по конкурентным ценам в точно указанные сроки.

Срок поставки со стоков в **Европе и Америке – от 3 до 14 дней.**

Срок поставки из **Азии – от 10 дней.**

Благодаря развитой сети поставщиков, помогаем в поиске и приобретении экзотичных или снятых с производства компонентов.

Предоставляем спец цены на элементы для создания инженерных сэмплов.

Упорный труд, качественный результат дают нам право быть уверенными в себе и надежными для наших клиентов.

Наша компания это:

- Гарантия качества поставляемой продукции
- Широкий ассортимент
- Минимальные сроки поставок
- Техническая поддержка
- Подбор комплектации
- Индивидуальный подход
- Гибкое ценообразование

Наша организация особенно сильна в поставках модулей, микросхем, пассивных компонентов, ксайленсах (XC), EPF, EPM и силовой электроники.

Большой выбор предлагаемой продукции, различные виды оплаты и доставки, позволят Вам сэкономить время и получить максимум выгоды от сотрудничества с нами!

Перечень производителей, продукцию которых мы поставляем на российский рынок

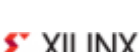

С удовольствием будем прорабатывать для Вас поставки всех необходимых компонентов по текущим запросам для скорейшего выявления групп элементов, по которым сотрудничество именно с нашей компанией будет для Вас максимально выгодным!

С уважением,

Менеджер отдела продаж ООО

«Трейд Электроникс»

Шишлаков Евгений

8 (495)668-30-28 доб 169

manager28@tradeelectronics.ru

<http://www.tradeelectronics.ru/>